

# Monitoring Physical Threats in the Data Center

By Christian Cowan  
Chris Gaskins

White Paper #102

**APC**<sup>®</sup>  
Legendary Reliability<sup>®</sup>

## Executive Summary

Traditional methodologies for monitoring the data center environment are no longer sufficient. With technologies such as blade servers driving up cooling demands and regulations such as Sarbanes-Oxley driving up data security requirements, the physical environment in the data center must be watched more closely. While well understood protocols exist for monitoring physical devices such as UPS systems, computer room air conditioners, and fire suppression systems, there is a class of distributed monitoring points that is often ignored. This paper describes this class of threats, suggests approaches to deploying monitoring devices, and provides best practices in leveraging the collected data to reduce downtime.

# Introduction

Today's common techniques for monitoring the data center environment date from the days of centralized mainframes, and include such practices as walking around with thermometers and relying on IT personnel to "feel" the environment of the room. But as data centers continue to evolve with distributed processing and server technologies that are driving up power and cooling demands, the environment must be looked at more closely.

Rising power density and dynamic power variations are the two main drivers forcing changes in the monitoring methodology of IT environments. Blade servers have tremendously increased power densities and dramatically changed the power and cooling dynamics of the surrounding environments. Power management technologies have pushed the ability of servers and communication equipment to vary power draw (and therefore heat dissipation) based on computational load. This issue is described in detail in APC White Paper # 43, "Dynamic Power Variations in Data Centers and Network Rooms."

Although it is common to have sophisticated monitoring and alerting capabilities in physical equipment such as the UPS, computer room air conditioner (CRAC), and fire suppression systems, other aspects of the physical environment are often ignored. Monitoring of equipment is not enough – the surrounding environment must be viewed holistically and watched proactively for threats and intrusions. Such threats include excessive server intake temperatures, water leaks, and unauthorized human access to the data center or inappropriate actions by personnel in the data center.

Remote network locations such as branch offices, data rooms, and local point-of-sale locations further highlight the need for automated monitoring, where it is impractical and unreliable to have people physically present to check conditions such as temperature and humidity. With the introduction of unmanned network outposts, IT administrators must have reliable systems in place to know what is going on.

With today's technologies, monitoring systems can be configured to a level of detail that meets the data center's particular environmental and security demands – each rack can be considered a mini "data center" with its own requirements, with a monitoring strategy that may include multiple data collection points.<sup>1</sup>

This paper discusses physical threats that can be mitigated by distributed monitoring strategies, and offers guidelines and best practices for implementing sensors in the data center. It also discusses the use of data center design tools to simplify the specification and design process of these distributed monitoring systems.

---

<sup>1</sup> APC White Paper #100, "Management Strategy for Network-Critical Physical Infrastructure," addresses the issue of integrating a large number of rack-located monitor points into an existing enterprise management system (EMS) or building management system (BMS).

# What Are Distributed Physical Threats?

This paper addresses a subset of threats – *distributed physical threats* – that are of particular interest because they require deliberate and expert design to defend against them. To identify that subset, it will be helpful to briefly characterize the range of threats to the data center.

Data center threats can be classified into two broad categories, depending on whether they are in the realm of IT software and networking (**digital** threats) or in the realm of the data center's physical support infrastructure (**physical** threats).

## Digital threats

Digital threats are such things as hackers, viruses, network bottlenecks, and other accidental or malicious assaults on the security or flow of data. Digital threats have a high profile in the industry and the press, and most data centers have robust and actively maintained systems, such as firewalls and virus checkers, to defend against them. APC White Paper # 101, "Fundamental Principles of Network Security," reviews the basic safeguards against digital threats. *Digital threats are not the subject of this paper.*

## Physical threats

Physical threats to IT equipment include such things as power and cooling problems, human error or malice, fire, leaks, and air quality. Some of these, including threats related to power and some related to cooling and fire are routinely monitored by built-in capabilities of power, cooling, and fire suppression devices. For example, UPS systems monitor power quality, load, and battery health; PDUs monitor circuit loads; cooling units monitor input and output temperatures and filter status; fire suppression systems – the ones that are required by building codes – monitor the presence of smoke or heat. Such monitoring typically follows well understood protocols automated by software systems that aggregate, log, interpret, and display the information. Threats monitored in this way, by pre-engineered functionality designed into the equipment, do not require any special user expertise or planning in order to be effectively managed, as long as the monitoring and interpretation systems are well engineered. *These automatically-monitored physical threats are a critical part of a comprehensive management system, but are not the subject of this paper.*

However, certain kinds of physical threats in the data center – and they are serious ones – do not present the user with pre-designed, built-in monitoring solutions. For example, the threat of poor humidity levels can be anywhere in the data center, so the number and placement of humidity sensors is an important consideration in managing that threat. Such threats can potentially be **distributed anywhere throughout the data center, at variable locations that are particular to room layout and equipment positioning**. The distributed physical threats covered by this paper fall into these general categories:

- Air quality threats to IT equipment (temperature, humidity)
- Liquid leaks
- Human presence or unusual activity
- Air quality threats to personnel (foreign airborne substances)
- Smoke and fire from data center hazards<sup>2</sup>

**Figure 1** illustrates the distinction between digital and physical threats, and the further distinction in physical threats between those with pre-engineered equipment-based power/cooling monitoring and – the subject of this paper – distributed physical threats that require assessment, decisions, and planning to determine the type, location, and number of monitoring sensors. It is this latter type of physical threat that may risk neglect because of lack of knowledge and expertise in designing an effective monitoring strategy.

*Figure 1 – Threats to the data center*

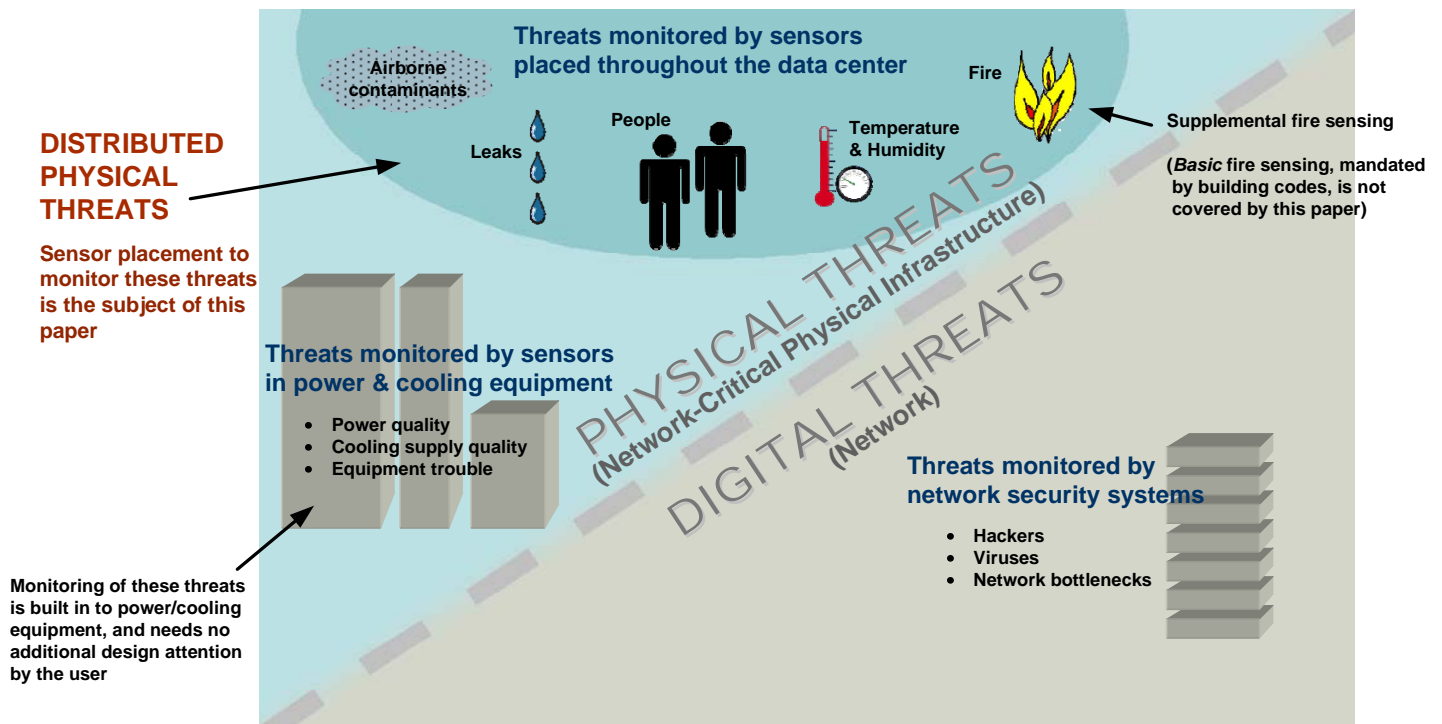

**Table 1** summarizes distributed physical threats, their impact on the data center, and the types of sensors used to monitor them.

<sup>2</sup> Basic room smoke/fire detection required by building codes is governed by specific legal and safety regulations, and is not the subject of this paper. This paper covers *supplemental* smoke detection particular to hazards in the data center, beyond what is required by building codes.

*Table 1 – Distributed physical threats*

Threat	Definition	Impact on Data Center	Types of Sensors
<b>Air temperature</b>	Room, rack, and equipment air temperature	Equipment failure and reduced equipment life span from temperature above specification and/or drastic temperature changes	Temperature sensors
<b>Humidity</b>	Room and rack relative humidity at specific temperature	Equipment failure from static electricity buildup at low humidity points Condensation formation at high humidity points	Humidity sensors
<b>Liquid leaks</b>	Water or coolant leaks	Liquid damage to floors, cabling and equipment Indication of CRAC problems	Rope leak sensors Spot leak sensors
<b>Human error and personnel access</b>	Unintentional wrongdoing by personnel Unauthorized and/or forced entry into the data center with malicious intent	Equipment damage and data loss Equipment downtime Theft and sabotage of equipment	Digital video cameras Motion sensors Rack switches Room switches Glass-break sensors Vibration sensors
<b>Smoke / Fire</b>	Electrical or material fire	Equipment failure Loss of assets and data	Supplemental smoke sensors
<b>Hazardous airborne contaminants</b>	Airborne chemicals such as hydrogen from batteries and particles such as dust	Dangerous situation for personnel and/or UPS unreliability and failure from release of hydrogen Equipment failure from increased static electricity and clogging of filters/fans from dust buildup	Chemical / hydrogen sensors Dust sensors

## Sensor Placement

Various types of sensors can be used to provide early warning of trouble from the threats described above. While the specific type and number of sensors may vary depending upon budget, threat risk, and the business cost of a breach, there is a minimum essential set of sensors that makes sense for most data centers. **Table 2** shows guidelines for this basic recommended set of sensors.

Table 2 – Guidelines for basic sensors







Sensor Type	Location	General Best Practice	Comments	Applicable Industry Guidelines	Example
Temperature sensors	Rack	At top, middle, and bottom of the front door of each IT rack, to monitor inlet temperature of devices in rack	In wiring closets or other open rack environments, temperature monitoring should be as close as possible to equipment inlets	ASHRAE Guidelines <sup>3</sup>	
Humidity sensors	Row	One per cold aisle, at the front of a rack in the middle of the row	Since CRAC units provide humidity readings, location of row-based humidity sensors may need to be adjusted if too close to CRAC output	ASHRAE Guidelines	
Rope leak sensors Spot leak sensors	Room	Leak rope placement around each CRAC system, around cooling distribution units, and under raised floors, and any other leak source (such as pipes)	Spot leak sensors for monitoring fluid overflows in drip pans, monitoring in smaller rooms / closets and at any low spots	No industry standard	
Digital video cameras	Room and Row	Strategically placed according to data center layout covering entry / exit points and a good view of all hot and cold aisles; ensure complete required field of view is covered	Monitoring and recording of normal access as well as unauthorized or after-hours access with video surveillance software	No industry standards	
Room switches	Room	Electronic switch at every entry door to provide audit trail of room access, and to limit access to specific people at specific times	Integrating room switches into the facility system may be desirable and can be achieved through a communications interface	HIPPA and Sarbanes-Oxley <sup>4</sup>	

In addition to the essential sensors shown in **Table 2**, there are others that can be considered optional, based on the particular room configuration, threat level, and availability requirements. **Table 3** lists these additional sensors along with best practice guidelines.

<sup>3</sup> ASHRAE TC9.9 Mission Critical Facilities, "Thermal Guidelines for Data Processing Environments," 2004.

<sup>4</sup> CSO Fiona Williams, Deloitte & Touche security services, says "Physical security does fall under the Sarbanes-Oxley requirements. It is a critical component of the infosec program as well as general computer controls. It falls within sections 302 and 404, which require that management evaluate and assert that the internal controls are operating effectively." <http://www.csoonline.com/read/100103/counsel.html> (accessed on April 20, 2006)

*Table 3 – Guidelines for additional, situation-dependent sensors*

Sensor Type	Location	General Best Practice	Comments	Applicable Industry Guidelines	Example
Supplemental smoke sensors	Rack	Rack level “very early smoke detection” (VESD) to provide advanced warning of problems in highly critical areas or areas without dedicated smoke sensors <sup>5</sup>	When rack-level supplemental smoke detection exceeds budget, placing VESD on the input of each CRAC provides some degree of early warning	No industry standards	
Chemical / hydrogen sensors	Room	When VRLA batteries are located in the data center, it is not necessary to place hydrogen sensors in the room because they do not release hydrogen in normal operation (as wet cell batteries do)	Wet cell batteries in a separate battery room are subject to special code requirements	Draft IEEE / ASHRAE Guide <sup>6</sup>	
Motion sensors	Room and Row	Used when budget constraints don’t allow for digital camera installation, which is best practice (see Table 2)	Motion sensors are a lower cost alternative to digital video cameras for monitoring human activity	No industry standards	
Rack switches	Rack	In high traffic data centers, electronic switches on the front and rear door of every rack to provide audit trail of access and to limit critical equipment access to specific people at specific times	Integrating rack switches into the facility system may be desirable and can be achieved through a communications interface	HIPPA and Sarbanes-Oxley	
Vibration sensors	Rack	In high traffic data centers, vibration sensor in each rack to detect unauthorized installation or removal of critical equipment	Vibration sensors in each rack can also be used to sense when people move racks	No industry standards	
Glass-break sensors	Room	Glass-break sensor on every data center window (either external, or internal to hallway or room)	Best if used in conjunction with video surveillance cameras	No industry standards	

<sup>5</sup> Assumes the existence of a separate fire detection system to meet building codes

<sup>6</sup> IEEE/ASHRAE, “Guide for the Ventilation and Thermal Management of Stationary Battery Installations,” Draft out for ballot later in 2006

## Aggregating Sensor Data

With the sensors selected and placed, the next step is the collection and analysis of the data received by the sensors. Rather than send all sensor data directly to a central collection point, it is usually better to have aggregation points distributed throughout the data center, with alert and notification capabilities at each aggregation point. This not only eliminates the single-point-of-failure risk of a single central aggregation point, but also supports point-of-use monitoring of remote server rooms and telecom closets.<sup>7</sup> The aggregators communicate, through the IP network, with a central monitoring system (**Figure 2**).

*Figure 2 – Aggregating the sensor data*

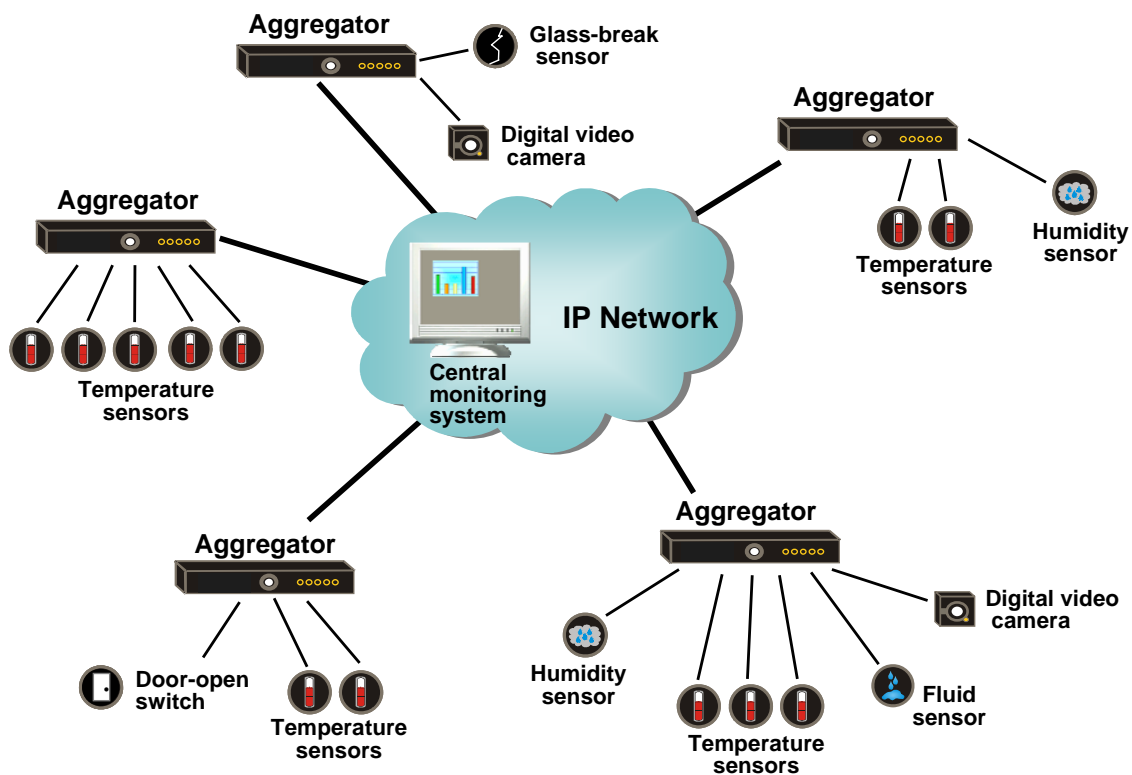

Individual sensors do not typically connect individually to the IP network. Instead, the aggregators interpret the sensor data and send alerts to the central system and/or directly to the notification list (see next section). This distributed monitoring architecture dramatically reduces the number of network drops required and reduces the overall system cost and management burden. Aggregators are typically assigned to physical areas within the data center and aggregate sensors from a limited area in order to limit sensor wiring complexity.

<sup>7</sup> This architecture of multiple aggregators, each with alert and notification capability for the sensors it supports, is sometimes called “distributed intelligence at the edge.”

## “Intelligent” Action

Sensors supply the raw data, but equally important is the interpretation of this data to perform alerting, notification, and correction. As monitoring strategies become more sophisticated, and sensors proliferate throughout the well-monitored data center, “intelligent” processing of this potentially large amount of data is critical. The most effective and efficient way to collect and analyze sensor data and trigger appropriate action is through the use of “aggregators” as described in the previous section.

It is essential to be able to filter, correlate, and evaluate the data to determine the best course of action when out-of-bounds events occur. Effective action means alerting the right people, via the right method, with the right information. Action is taken in one of three ways:

- **Alerting** on out-of-bounds conditions that could threaten specific devices, racks, or the data center as a whole
- Automatic **action** based on specified alerts and thresholds
- **Analysis and reporting** to facilitate improvements, optimization, and fault / failure measurements

### Alerting

There are three things to establish when setting alerts: **alarm thresholds** – at what value(s) should the alarms trigger; **alerting methods** – how the alert should be sent and to whom; and **escalation** – do certain types of alarms require a different level of escalation to resolve?

**Alarm Thresholds** – For each sensor, acceptable operating conditions should be determined and thresholds configured to produce alarms when readings exceed those operating conditions. Ideally, the monitoring system should have the flexibility to configure multiple thresholds per sensor in order to alert at informational, warning, critical, and failure levels. In addition to single-value thresholds, there should be triggering conditions such as over-threshold for a specified amount of time, rate of increase, and rate of decrease. In the case of temperature, alerting on rate of change provides a quicker indication of failure than a snapshot temperature value.

Thresholds must be set carefully to ensure maximum usefulness. There may be different thresholds that cause different alerts based on the severity of the incident. For example, a humidity threshold event might result in an email to the IT administrator, whereas a smoke sensor might trigger an automatic call to the fire department. Likewise, different threshold levels will warrant different escalation paths. For example, an unauthorized rack access event might escalate to the IT administrator whereas a forced entry event might escalate to the IT director.

Thresholds should be globally set to default values, and then individually adjusted based on IT equipment specifications and the sensor mounting location relative to equipment location (for example, a sensor

located close to a server power supply should alarm at a higher value than a sensor located close to the air inlet of a server). **Table 4** lists suggested default thresholds for temperature and humidity, based on ASHRAE TC9.9. In addition to these thresholds, it is important to monitor the rate of change of temperature. A temperature change of 10 °F (5.6 °C) in a 5-minute period is a likely indication of a CRAC failure.

*Table 4 –Suggested temperature & humidity sensor thresholds<sup>8</sup>*

Sensor	High Threshold	Low Threshold
Air temperature	77 °F (25 °C)	68 °F (20 °C)
Humidity	55% relative humidity	40% relative humidity

**Alerting Methods** – Alert information can be dispatched in a variety of different ways such as email, SMS text messages, SNMP traps, and posts to HTTP servers. It is important that the alerting systems be flexible and customizable so that the right amount of information is successfully delivered to the intended recipient. Alert notifications should include information such as the user-defined name of the sensor, sensor location, and date/time of alarm.

**Alert Escalation** – Some alarms may require immediate attention. An intelligent monitoring system should be able to escalate specific alarms to higher levels of authority if the issue is not resolved within a specified amount of time. Alert escalation helps to ensure that problems are addressed on a timely basis, before small issues cascade into larger issues.

The following are examples of both useful and not-so-useful alerts:

*Temperature sensor #48 is over threshold* – Not very useful since it doesn't indicate where sensor #48 is located

*Web server X is in danger of overheating* – More useful since the specific server is identified

*Door sensor has been activated* – Not very useful since the specific door was not identified

*Door X at location Y has been opened, and a picture of the person opening the door was captured* – Very useful since it includes the door identification, door location, and a photograph of the incident

<sup>8</sup> ASHRAE TC9.9 recommendation for class 1 environments, which are the most tightly controlled and would be most appropriate for data centers with mission critical operations.

## Acting on the data

Collecting sensor data is only the first step, and if the data center manager relies on manual response alone, the data will not be leveraged to maximum advantage. There are systems available that act automatically based on user-specified alerts and thresholds. In order to implement such “smart” automation, the following must be assessed:

**Alert actions** – Based on the severity level of an alert, what automated actions should take place? These automated actions could be personnel notifications, or they could be corrective actions such as triggering dry contact points to turn on or off devices such as fans or pumps.

**Ongoing real-time visibility of sensor data** – The ability to view individual sensor “snapshot” readings is a basic requirement. However, the ability to view individual sensor *trends* in real time provides a much better “picture” of the situation. Interpretation of these trends allows administrators to detect broader issues and correlate data from multiple sensors.

Alerting systems should provide more than just basic threshold violation notifications. For example, some monitoring systems allow administrators to include additional data with the alerts. This additional data might be captured video, recorded audio, graphs, and maps. A rich alerting system of this type allows administrators to make more informed decisions because of the contextual data included with the alert. In some cases, too much information may need to be distilled to what is useful. For example, in a high-traffic data center, it would be a nuisance to have an alert every time there was motion in the data center. There may be instances where certain information is blocked out or “masked” in the interest of security. For example, a video including the view of a keyboard could block out individuals typing passwords. The following are examples of “intelligent” interpretation and action:

- On a temperature threshold breach, automatically turn on a fan or CRAC
- Remotely provide access to specific racks with electronic door locks, based on whose face is on real-time video surveillance
- When water is detected in a remote data center, automatically turn on a sump pump
- When motion is detected in the data center after normal hours of operation, automatically capture video and alert the security guards
- When a glass break is detected after hours, notify security guards and sound audible alarm
- When a door switch indicates that a rack door has been open for more than 30 minutes (indicating the door was not closed properly) send alarm to administrator to check the door

## Analysis and Reporting

Intelligent monitoring systems should include not only short term trending of sensor data, but also long term historical data as well. Best-of-breed monitoring systems should have access to sensor readings from weeks, months, or even years past and provide the ability to produce graphs and reports of this data. The graphs should be able to present multiple types of sensors on the same report for comparison and analysis. The reports should be able to provide low, high, and average sensor readings in the selected time frame across various groups of sensors.

Long term historical sensor information can be used in a variety of ways – for example, to illustrate that the data center is at capacity not because of physical space, but due to inadequate cooling. Such information could be used to extrapolate future trends as more and more equipment is added to a data center, and could help predict when the data center will reach capacity. Long term trending analysis could be used at the rack level to compare how equipment from different manufacturers in different racks produce more heat or run cooler, which may influence future purchases.

Sensor readings captured by the monitoring system should be exportable to industry-standard formats, enabling the data to be used in off-the-shelf as well as custom reporting and analysis programs.

## Design Method

While the specification and design of a threat monitoring system may appear complex, the process can be automated with data center design tools such as APC's InfraStruXure Designer. Design tools such as this allow the user to input a simple list of preferences, and can automatically locate the appropriate number of sensors and aggregation devices. Summary reports provide parts lists and installation instructions for the recommended sensors. These data center design tools use algorithms and established rules based on best practices and industry standards to recommend specific configurations based on density, room layout, room access policies, and user-specific monitoring requirements.

For example, the following user-specified preferences might influence the design of the threat monitoring system, based on the level of data center traffic and access:

**High traffic/access** – If the data center is accessed by many individuals, each with different applications and functions in the data center, the design tool would suggest rack switches on every rack to allow access only to individuals needing access to the respective racks.

**Low traffic/access** – If the data center is accessed by a select few individuals, each with responsibility for all data center functions, the design tool would not suggest rack switches to control access to separate racks; rather, a room door switch would be sufficient to limit access to the room by other individuals.

# Sample Sensor Layout

A sample data center layout is shown in **Figure 3**, illustrating where monitoring devices would be located based on the best practices described in this paper.

Figure 3 – Sample sensor layout

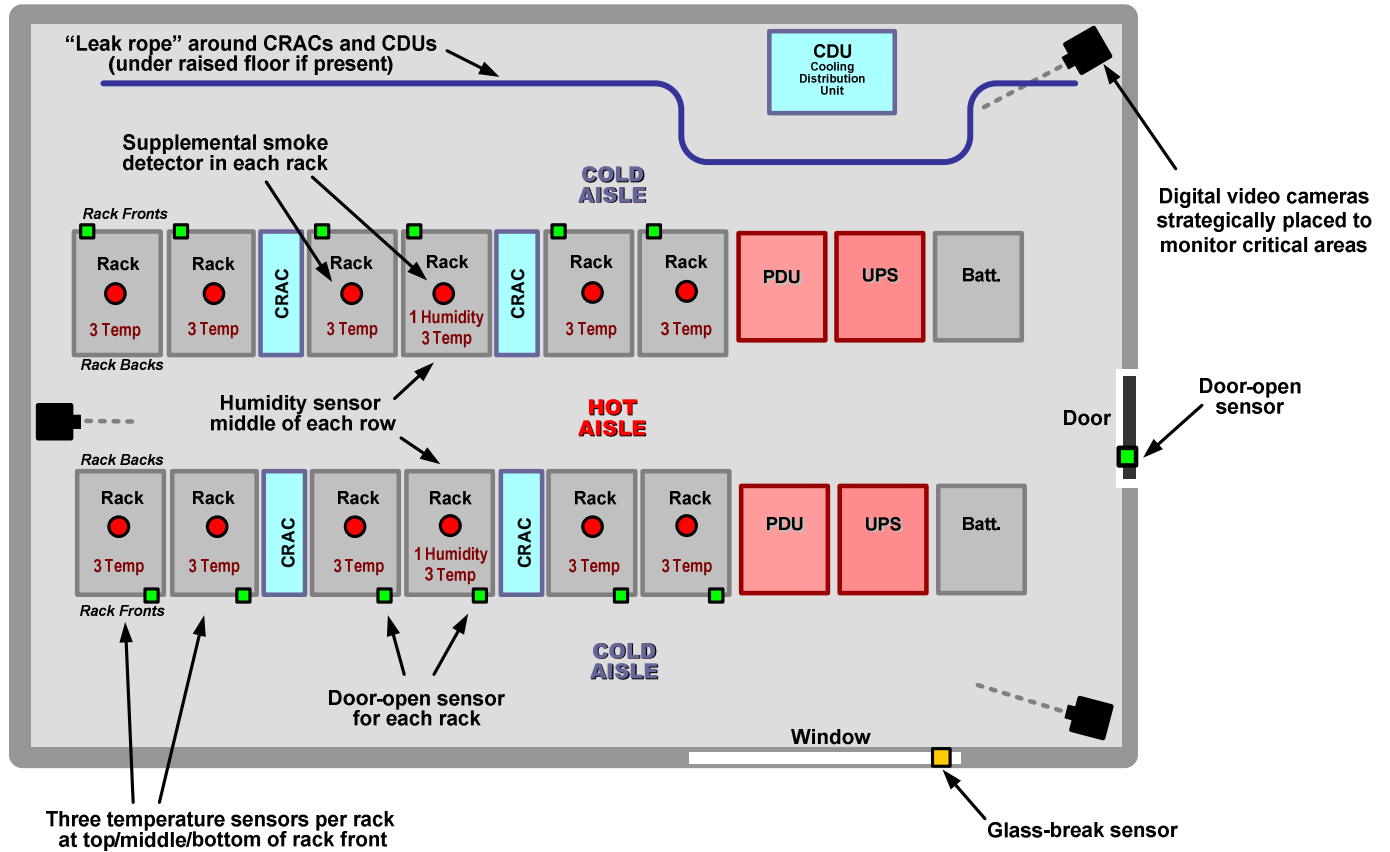

## Conclusion

Safeguarding against distributed physical threats is crucial to a comprehensive security strategy. While the placement and methodology of sensing equipment requires assessment, decision, and design, best practices and design tools are available to assist in effective sensor deployment.

In addition to proper type, location, and number of sensors, software systems must also be in place to manage the collected data and provide logging, trend analysis, intelligent alert notifications, and automated corrective action where possible.

Understanding the techniques for monitoring distributed physical threats enables the IT administrator to fill critical gaps in overall data center security, and to keep physical security aligned with changing data center infrastructure and availability goals.

## About the Authors

**Christian Cowan** is a product manager for APC's environmental and security product line. He has been in the IT and NCPI industries for 15 years, and is a member of IEEE. He holds a Bachelor of Science degree in electrical engineering from Villanova University and an MBA from the University of Rhode Island.

**Chris Gaskins** is a 15-year veteran of the high tech industry where he has held a range of jobs in engineering, product management, and support. His technical background includes experience with PC-based servers, systems management, network management, and digital and physical security. He is currently the product line manager for environmental and security products at APC, which includes the NetBotz family of products. Before this, Chris was the Vice President of Engineering for AppGate, Inc. where he led a team of engineers developing application layer VPN systems. He holds a Bachelor of Science degree in Computer Science from Berry College in Rome, Georgia.